



SEAFIRST workmanship with
Fresh Innovative Reliable Safe Truthful

Hydraulic Steering



Hydraulic Steering

- For Outboard Motor
- For Stern Drive
- For Inboard

CONTENTS

Hydraulic Steering For Outboard 3

1. Complete Package System : MO 350H type 4
2. Complete Package System : MO 350V type 5
3. Complete Package System : MO 100H type 6
4. Dual Station Kit 7
5. Order Guide : MO 350 type 8

Hydraulic Steeting For Stern Drive 9

1. Complete Package System : MS 250S-U1 10
2. Complete Package System : MS 250S-B1 11

Hydraulic Steering For Inboard 12

1. Complete Package System : MI - N type 13
2. Complete Package System : MI - H type 14

Hydraulic Steering Component 15

1. Helm Pump 16
2. Cylinder 18
3. Tie Bar 22
4. Hose & Hose Coupling 23
5. Fitting 24
6. Oil Bleeding Kit & Tiller Arm & Oil 25
7. Liquid Tie bar Alignment Valve 26
8. Steering Wheel 26
9. Rudder Angle Indicators System 27

HYDRAULIC STEERING FOR OUTBOARD



COMPLETE PACKAGED SYSTEM

MO 350H type



Universal cylinder included



Adjustable Stainless Steel Elbow Fittings. (O-ring type, part number HLO14N0S, refer to the page 24)

Standard wheel turns : 5.3 lock to lock
For more or less wheel turns, ask your distributor or manufacturer

Steering kits includes

Model	Description
NSH 025 Helm Pump	Front Mount Helm pump 25cc
SOC 3520H type Cylinder	Front Mount Outboard cylinder. When ordering, specify the engine model.
SF OIL 15 Hydraulic Oil	Hydraulic oil 1 liter x 2 bottles. SAE NO 15.
NH 06-SS-07 Hydraulic Hose	Hydraulic Hose 3/8, 7 meter x 2pcs
Accessories included	Helm pump fittings, Helm pump mounting hardware kit, Accessories kit OAK-100 (Bleed tube, Funnel, Oil supply tube)

The Steering Wheel is not included in the package.

Application Guide – Single Engine

System Model	Applicable Outboard Motors	Cylinder
MO 350H - R1	Yamaha 4stroke : From 75hp to 350hp Yamaha 2stroke : 50hp, 60hp and From 100hp to 250hp Suzuki 4stroke : From 70hp to 300hp Honda 4stroke : From BF 50 to BF 250 except old 130hp and BF 115A (carburettor) Mercury : From 50hp to 250hp except old 4stroke 75hp and 115hp Tohatsu : M120, M140 Evinrude : From 65hp to 300hp	SOC 3520H-R1

* For old 4stroke from 75hp to 115hp Mercury Engine, contact to your distributor or dealer.

COMPLETE PACKAGED SYSTEM

MO 350V type



**Easy installation
for limited space**



Standard wheel turns : 5.3 lock to lock
For more or less wheel turns, ask your distributor or manufacturer

Adjustable Stainless Steel Elbow Fittings.
(O-ring type, part number HLO14N0S,
refer to the page 24)

Steering kits includes

Model	Description
NSH 025 Helm Pump	Front Mount Helm pump 25cc
SOC 3520V type Cylinder	Front Mount Outboard cylinder. When ordering, specify the engine model.
SF OIL 15 Hydraulic Oil	Hydraulic oil 1 liter x 2 bottles. SAE NO 15.
NH 06-SS-07 Hydraulic Hose	Hydraulic Hose 3/8, 7 meter x 2pcs
Accessories included	Helm pump fittings, Helm pump mounting hardware kit, Accessories kit OAK-100 (Bleed tube, Funnel, Oil supply tube)

The Steering Wheel is not included in the package.

Application Guide – Single Engine

System Model	Applicable Outboard Motors	Cylinder
MO 350V - Y1	Yamaha 4stroke : From 75hp to 350hp Yamaha 2stroke : From 100hp to 250hp Suzuki 4stroke : From 70hp to 300hp	SOC 3520V-Y1
MO 350V - H1	Honda 4stroke : From BF 70 to BF 250 except old 130hp and BF 115A (carburettor)	SOC 3520V-H1
MO 350V - Y4	Yamaha 4stroke : From 30hp to 60hp Yamaha 2stroke : From 50hp to 95hp	SOC 3520V-Y4
MO 350V - H5	Honda 4stroke : BF 115A carburettor (old) and BF 130A (old)	SOC 3520V-H5

COMPLETE PACKAGED SYSTEM

MO 100H type



For small engine
under 95hp



Standard wheel turns : 4.5 lock to lock

Steering kits includes

Model	Description
NSH 018 Helm Pump	Front Mount Helm pump 18cc
SOC 2512H Cylinder	Front Mount Outboard cylinder. When ordering, specify the engine model.
SF OIL 15 Hydraulic Oil	Hydraulic oil 1 liter x 2 bottles. SAE NO 15.
NH 04-SS-06 Hydraulic Hose	Hydraulic Hose 1/4, 6 meter x 2pcs
Accessories included	Helm pump fittings, Helm pump mounting hardware kit, Accessories kit OAK-100 (Bleed tube, Funnel, Oil supply tube)

The Steering Wheel is not included in the package.

Application Guide – Single Engine

System Model	Applicable Outboard Motors	Cylinder
MO 100H	Yamaha 4stroke : From 20hp to 90hp Yamaha 2stroke : From 30hp to 95hp Honda 4stroke : From 20hp to 70hp Suzuki 4stroke : From 20hp to 70hp Mercury : From 30hp to 60hp Tohatsu 4stroke : Up to BFT 90hp Tohatsu 2stroke : Up to M 90hp	SOC 2512H

Caution : Cut the Wing Nut type transom mount clamping screw if any.
It could be interfaced with cylinder when fully trim.

DUAL STATION KIT

DUAL STATION KIT

Part No : DHK-14-18, DHK-38-25

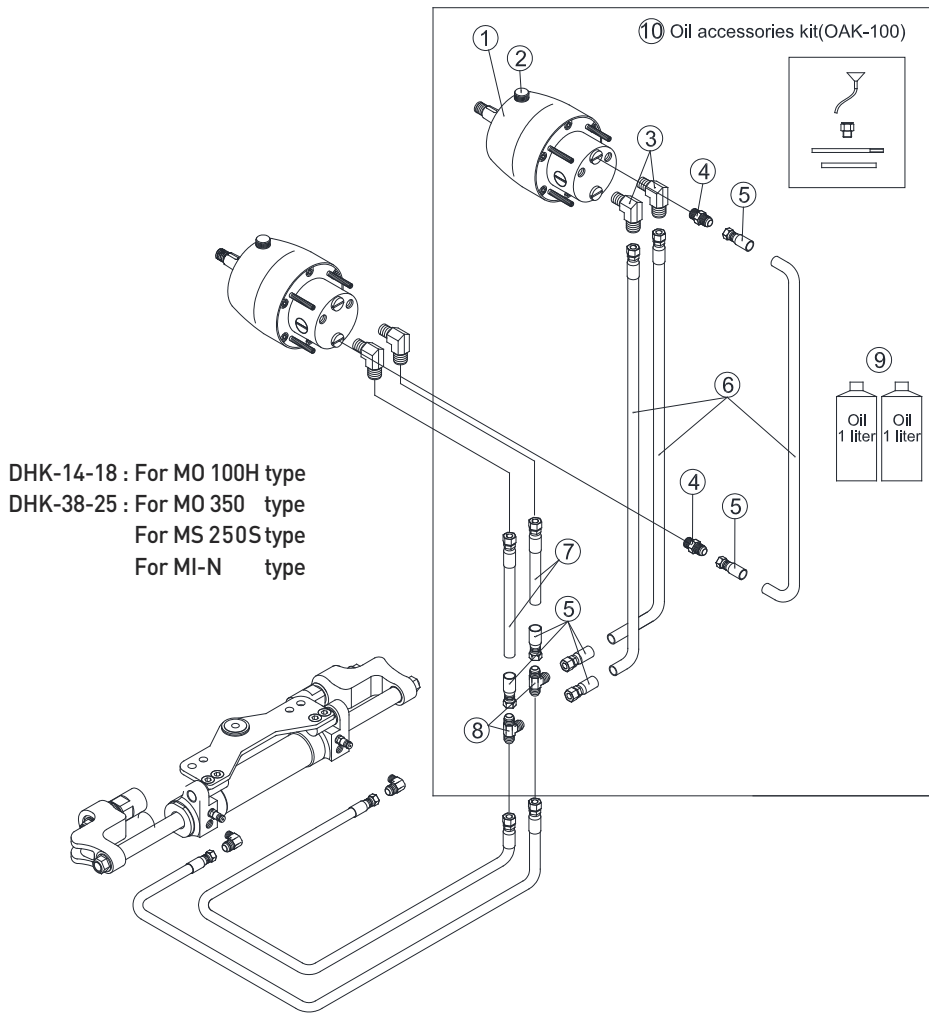

Dual Steering kits includes

NO	Description	Dual station1/4 DHK-14-18	Dual station 3/8 DHK-38-25	Q, TY
1	Helm pump [Select Model]	NSH-018	NSH-025	1
2	Cap (Ø1)	C0500126	C0500126	1
3	Elbow fitting(O-ring)	HLO14H0	HLO14N0S	2
4	Straight fitting(O-ring)	HSO14H0	HSO14N0	2
5	Campuka / Reusable	CPK0414	C3520149	6
6	Hose -30M	NH04-SS-30	NH06-SS-30	1
7	Hose -04M	NH04-SS-04	NH06-SS-04	1
8	Tee fitting	HTH300	HTN300	2
9	OIL (1LITER)	SF OIL 15	SF OIL 15	2
10	OIL Accessories Kit	OAK-100	OAK-100	1



ORDER GUIDE

MO 350V (H) – Single engine, Single Cylinder

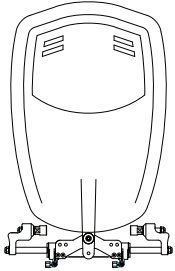
System	Application	Wheel Turns	Components	Model	Q'ty	Remark
	Up to 350HP	5.3	Cylinder Helm Pump Hose Oil Accessories kit	SOC 3520 NSH 025 NH 06-SS-07 SF OIL 15 OAK-100	1 1 2 2 1	MO 350V MO 350H Package kit

For a second station, add below : Refer to Dual Station Kit. Page 7

MO 350VT1 (HT1) – Twin engine, Single Cylinder

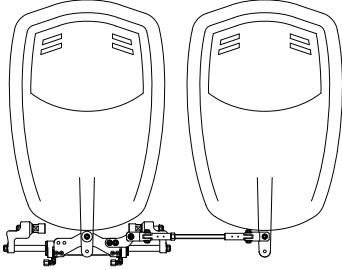
System	Application	Wheel Turns	Components	Model	Q'ty	Remark
	Up to 600HP (counter rotating engine) Up to 450HP (non-counter rotating engine)	5.3	Cylinder Helm Pump Hose Oil Accessories kit Tie Bar	SOC 3520 NSH 025 NH 06-SS-07 SF OIL 15 OAK-100 TBK 800S	1 1 2 2 1 1	MO 350VT1 MO 350HT1 Package kit

For a second station, add below : Refer to Dual Station Kit. Page 7

MO 350VT2 (HT2) – Twin engine, Two Cylinder

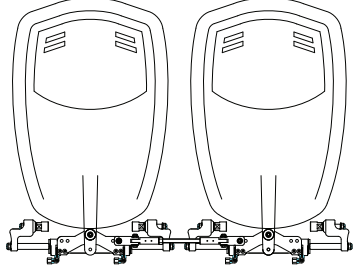
System	Application	Wheel Turns	Components	Model	Q'ty	Remark
	Up to 700HP (counter rotating engine) Up to 600HP (non-counter rotating engine)	10.6	Cylinder Helm Pump Hose Hose T fitting Oil Accessories kit Tie Bar	SOC 3520 NSH 025 NH 06-SS-07 NH 06-SS-01 HT14NNS SF OIL 15 OAK-100 TBK 800T	2 1 2 2 2 4 1 1	MO 350VT2 MO 350HT2 Package kit

For a second station, add below : Refer to Dual Station Kit. Page 7

HYDRAULIC STEERING FOR STERN DRIVE



COMPLETE PACKAGED SYSTEM

MS 250S-U1



For power assist stern drive



Wheel turn 5.4 / 4.4

Steering kits includes

Model	Description
NSH 030 Helm Pump	Front Mount Helm pump 30cc
SSC 3214U Cylinder	Stern drive cylinder, Unbalanced
SF OIL 15 Hydraulic Oil	Hydraulic oil 1 liter x 3 bottles. SAE NO 15.
NH 06-SS-20 Hydraulic Hose	Hydraulic Hose 3/8, 20 meter x 1pcs, including two Reusable hose coupling
Accessories included	Helm pump fittings, Helm pump mounting hardware kit, Accessories kit OAK-100 (Bleed tube, Funnel, Oil supply tube)

The Steering Wheel is not included in the package.

Application Guide, for Power Assist stern drive

System Model	Applicable Stern drive - power assist		Remark
	Maker	Model	
MS 250S-U1	MERCUISER	MERCUISER 1	Power Assist stern drive
		ALPHA	
		BRAVO ONE	
		BRAVO TWO	
		BRAVO THREE	
	VOLVO	280	
		290	
		DP-S	
	BMW	ALL	
	OMC	COBRA	
		KING COBRA	
	YAMAHA	POWER ASSIST ALL	

COMPLETE PACKAGED SYSTEM

MS 250S-B1



For Non-power assist stern drive



Wheel turn 4.4

Steering kits includes

Model	Description
NSH 030 Helm Pump	Front Mount Helm pump 30cc
SSC 3214B Cylinder	Stern drive cylinder, Balanced
SF OIL 15 Hydraulic Oil	Hydraulic oil 1 liter x 3 bottles. SAE NO 15.
NH 06-SS-20 Hydraulic Hose	Hydraulic Hose 3/8, 20 meter x 1pcs, including two Reusable hose coupling
Accessories included	Helm pump fittings, Helm pump mounting hardware kit, Accessories kit OAK-100 (Bleed tube, Funnel, Oil supply tube)

The Steering Wheel is not included in the package.

Application Guide, for Non-Power Assist stern drive

System Model	Applicable Stern drive - non power assist		Remark
	Maker	Model	
MS 250S-B1	MERCUISER	ALPHA	Non - Power Assist stern drive
		BRAVO ONE	
		BRAVO TWO	
		BRAVO THREE	
	VOLVO	280	
		290	
		DIESEL	

HYDRAULIC STEERING FOR INBOARD



COMPLETE PACKAGED SYSTEM

MI - N type



Steering kits includes

Model	Description
NSH-XXX Helm Pump	Front Mount Helm pump
IOC -40XX, 50XX CYLINDER	Single Straight Cylinder.
SF OIL 15 Hydraulic Oil	SAE NO 15, Hydraulic oil 1 liter x 2 bottles for MI 34N~61N 1 liter x 4 bottles for MI 75N~117N
NH 06-SS-20 Hydraulic Hose	Hydraulic Hose 3/8", 20 meter x 1pc, Reusable Hose Coupling x 2pcs
Accessories included	Helm pump fittings, Helm pump mounting hardware kit, Accessories kit OAK-100 (Bleed tube, Funnel, Oil supply tube)

The Steering Wheel is not included in the package.

Application Guide

Complete Model	System Basic Components		Wheel turns Lock to lock	Recommend		Suitable Steering Wheel Size
	Cylinder	Helm Pump		torque kgf.m	engine power HP	
MI 34N	IOC-4020	NSH 022	5.5	34	75	Dia 350mm
MI 48N	IOC-4021	NSH 025	6.7	48	75	
MI 61N	IOC-4022	NSH 030	7.1	61	110	
MI 75N	IOC-5024	NSH 037	7.1	75	110	Dia 395mm
MI 96N	IOC-5025	NSH 044	7.7	96	140	
MI 117N	IOC-5026	NSH 044	9.3	117	180	

Torque at pressure 40kg/cm² and 35 degree

COMPLETE PACKAGED SYSTEM

MI - H type



Steering kits includes

Model	Description
HP4590T Helm Pump	REAR MOUNT HELM PUMP 48~85cc. Adjustable
IOC -50XX, 63XX CYLINDER	Single Straight Cylinder.
SF OIL 15 Hydraulic Oil	SAE NO. 15, Hydraulic oil 1 liter x 4 bottles.
NH 06-SS-20 Hydraulic Hose	Hydraulic Hose 3/8", 20 meter x 1pc, Reusable Hose Coupling x 2pcs
Accessories included	Helm pump fittings, Helm pump mounting hardware kit, Accessories kit OAK-200 (Bleed tube, Funnel, Oil supply tube)

The Steering Wheel is not included in the package.

Application Guide

Complete Model	System Basic Components		Wheel turns Lock to lock	Recommend		Suitable Steering Wheel Size
	Cylinder	Helm Pump		torque kgf.m	engine power HP	
MI 118H	IOC-5024	HP 4590T	3.1~5.5	118	180	Dia 600mm
MI 151H	IOC-5025	HP 4590T	4.0~7.0	151	250	
MI 185H	IOC-5026	HP 4590T	4.8~8.6	185	250	
MI 270H	IOC-6325	HP 4590T	7.1~12.5	270	250	
MI 329H	IOC-6326	HP 4590T	8.6~15.3	329	350	

Torque at pressure 63kg/cm² and 35 degree

HYDRAULIC STEERING COMPONENTS



HELM PUMP

NSH Helm pump

Model	Displacement		Lock valve	Steering Wheel
	cc / rev	cu.in / rev		
NSH 018	18	1.09	Built-in	Min Dia 260mm
NSH 022	22	1.34		Min Dia 350mm
NSH 025	25	1.52		Min Dia 350mm
NSH 030	30	1.83		Min Dia 350mm
NSH 037	37	2.25		Min Dia 395mm
NSH 044	44	2.68		Min Dia 395mm

Heavy Duty



NSH type

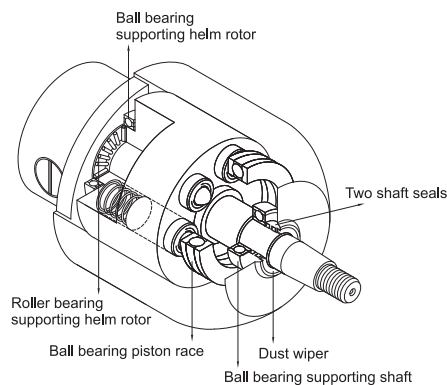

- Maximum durability
- SS 304 shaft
- At factory, the two ports on the rear are blocked tightly with black plugs while the two ports are blocked loosely with red plugs for an easy open to connect hydraulic hose fittings
- Fixed displacement
- Lock Valve Inbuilt
- Mounting Hardware and steering wheel mounting hardware supplied as standard
- Interconnecting ports (black plugs) for dual stations of steering
- Common dash hole mount for easy replacement with other brand

REAR VIEW

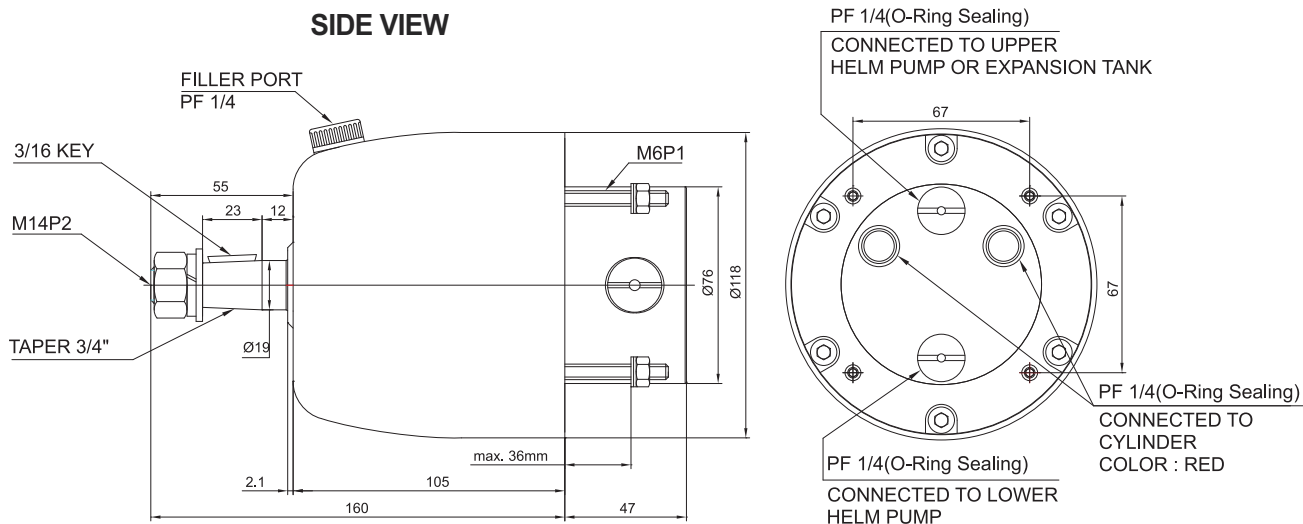

HELM PUMP

HP helm pump

- SS 304 shaft
- Adjustable Displacement from 48cc to 85cc
- Lock Valve Inbuilt
- Mounting Hardware and steering wheel mounting hardware supplied as standard
- Interconnecting ports for dual stations of steering
- Relief valve inbuilt

Heavy Duty



HP type

Model	Displacement		Shaft Spec	Key Spec	Remark
	cc / rev	cu.in / rev			
HP 4590T	48-85	2.9-5.1	Taper on 3/4 shaft	3/16" square	Built in lock valve

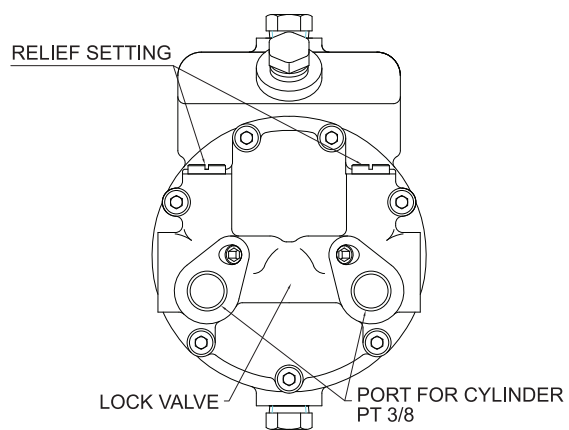
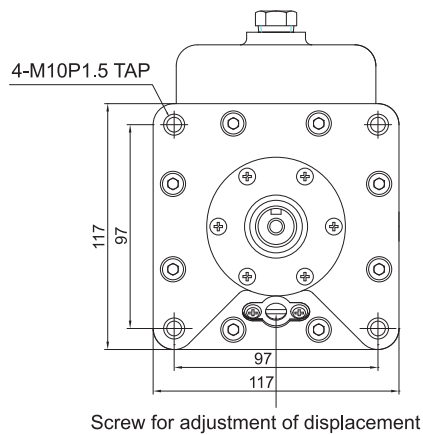

Anti-clockwise rotation for less displacement. Clockwise rotation for more displacement

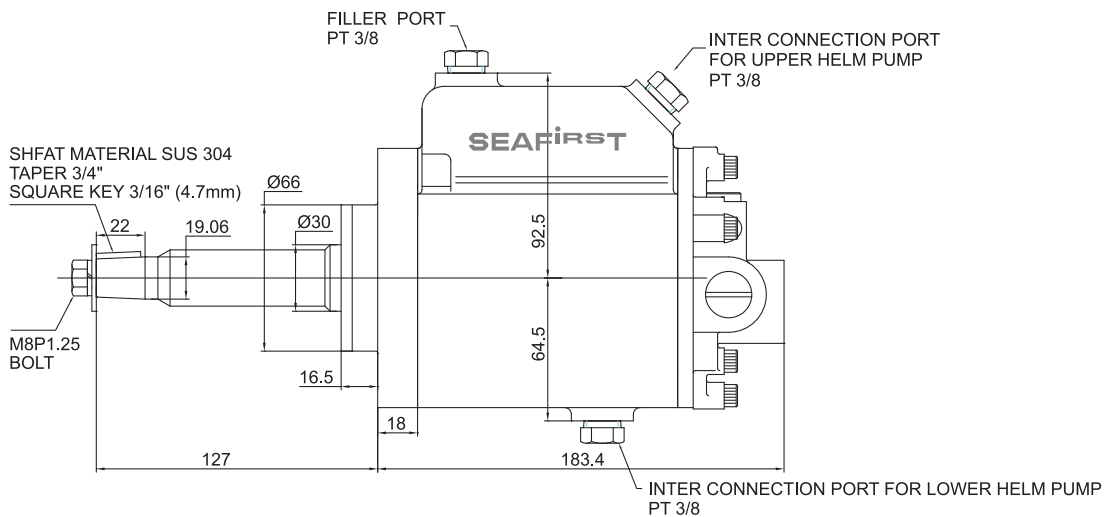

CYLINDER

SOC 3520H type - Outboard

Model : SOC 3520H-R1, SOC 3520H-R6	
Volume	132cc
Output force	454kg
Shaft diameter	20mm
Bore diameter	35mm
Stroke	203mm

- Stainless steel shaft with hard chrome plate
- Aluminum tube with anodizing
- Aluminum arms with anodizing
- Stainless steel lock nuts
- Compact Design for less space installation
- Install for single and multi engines
- Balanced cylinder : The number of turns lock to lock is equal port to starboard

SOC 3520H type - Outboard

Universal cylinder applicable for most of OBM



Adjustable Stainless Steel Elbow Fittings.
(O-ring type, part number HLO14N0S, refer to the page 24)

Shape of plate according to the Model

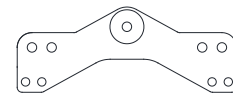

SOC 3520H-R1

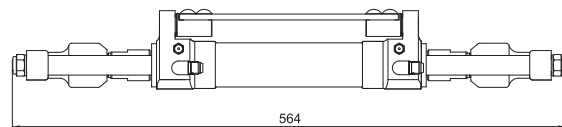
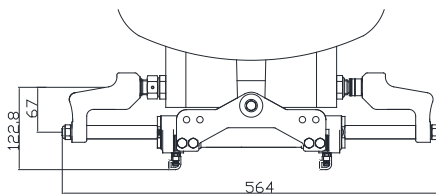

Splashwell Dimension Requirements

No of Cylinder	A	B	C	Min. engine center distance
1	570mm	152mm	127mm	N/A
2	1180mm	152mm	127mm	660mm

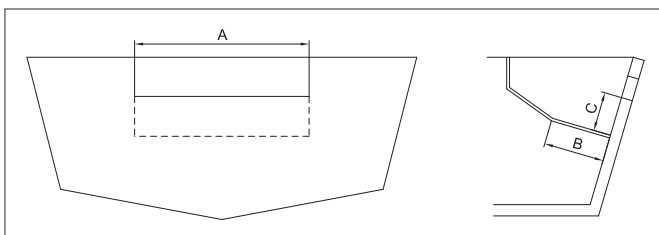

Note : Maximum transom thickness 76mm

CYLINDER

SOC 3520V type - Outboard

**Model : SOC 3520V-Y1, SOC 3520V-H1
SOC 3520V-Y4, SOC 3520V-H5**

Volume	132cc
Output force	454kg
Shaft diameter	20mm
Bore diameter	35mm
Stroke	203mm

- Stainless steel shaft with hard chrome plate
- Aluminum tube with anodizing
- Aluminum arms with anodizing
- Stainless steel lock nuts
- Compact Design for less space installation
- Install for single and multi engines
- Balanced cylinder : The number of turns lock to lock is equal port to starboard

It is unrestricted to install it in crawl space on both side of cylinder



Adjustable Stainless Steel Elbow Fittings.
(O-ring type, part number HLO14N0S, refer to the page 24)

Shape of plate according to the Model

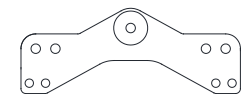

SOC 3520V-Y1, H1

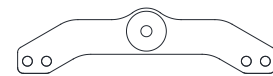

SOC 3520V-Y4



SOC 3520V-H5

It does not require Spacer for centering
It is self-centered

It only adjust Spacers here

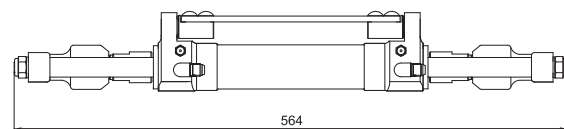
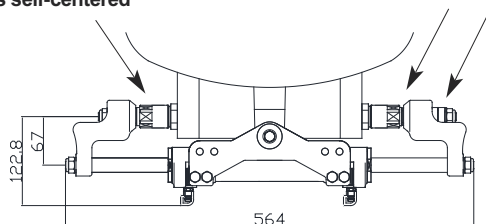

Splashwell Dimension Requirements

No of Cylinder	A	B	C	Min. engine center distance
1	570mm	152mm	127mm	N/A
2	1180mm	152mm	127mm	660mm

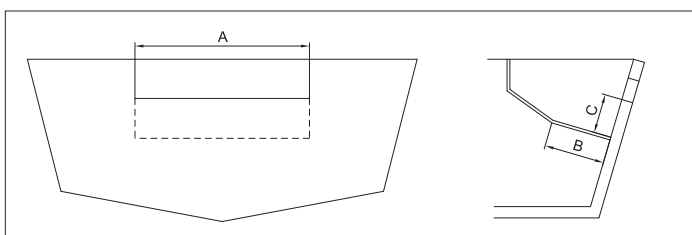

Note : Maximum transom thickness 76mm

CYLINDER

SOC 2512H Type - Outboard

Model : SOC 2512H Type	
Volume	83 cc
Stroke	220mm
Shaft diameter	12mm
Output force	264kg
Bore diameter	25mm

- Stainless steel shaft with hard chrome plate
- Aluminum tube with anodizing
- Aluminum arms with anodizing
- Stainless steel lock nuts
- Compact Design for less space installation
- Install for single and multi engines
- Balanced cylinder : The number of turns lock to lock is equal port to starboard

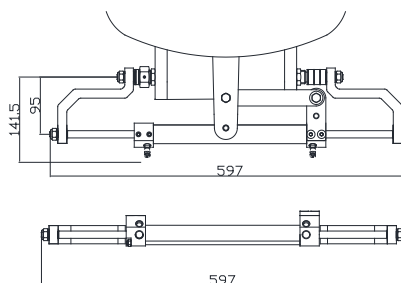

SSC 3214U type - Stern Drive SSC 3214B type - Stern Drive

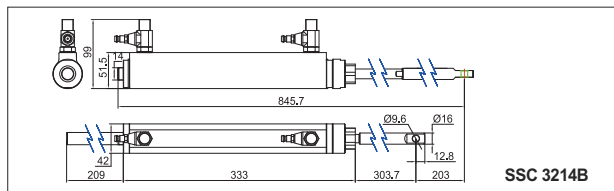
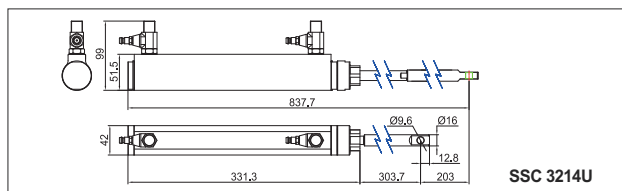

SPECIFICATIONS	SSC 3214U	SSC 3214B
Volume	163/132cc	132cc
Stroke	203mm	203mm
Shaft diameter	14mm	14mm
Torque		64kgm
Output force	455kg / 563kg	455kg
Bore diameter	32mm	32mm

CYLINDER

IOC Cylinder - Inboard

Cylinder	Bore	Stroke	Shaft	Oil Volume	Torque. Kgf.m		Port thread M
	mm	mm	mm	cc	At 40kg/cm ²	At 63kg/cm ²	
IOC-4020	40	127	20	120	34	54	PT 3/8
IOC-4021	40	178	20	168	48	75	PT 3/8
IOC-4022	40	229	20	215	61	97	PT 3/8
IOC-5024	50	178	25	262	75	118	PT 3/8
IOC-5025	50	229	25	337	96	151	PT 3/8
IOC-5026	50	279	25	411	117	185	PT 3/8
IOC-6325	63	229	25	600	171	270	PT 3/8
IOC-6326	63	279	25	734	209	329	PT 3/8

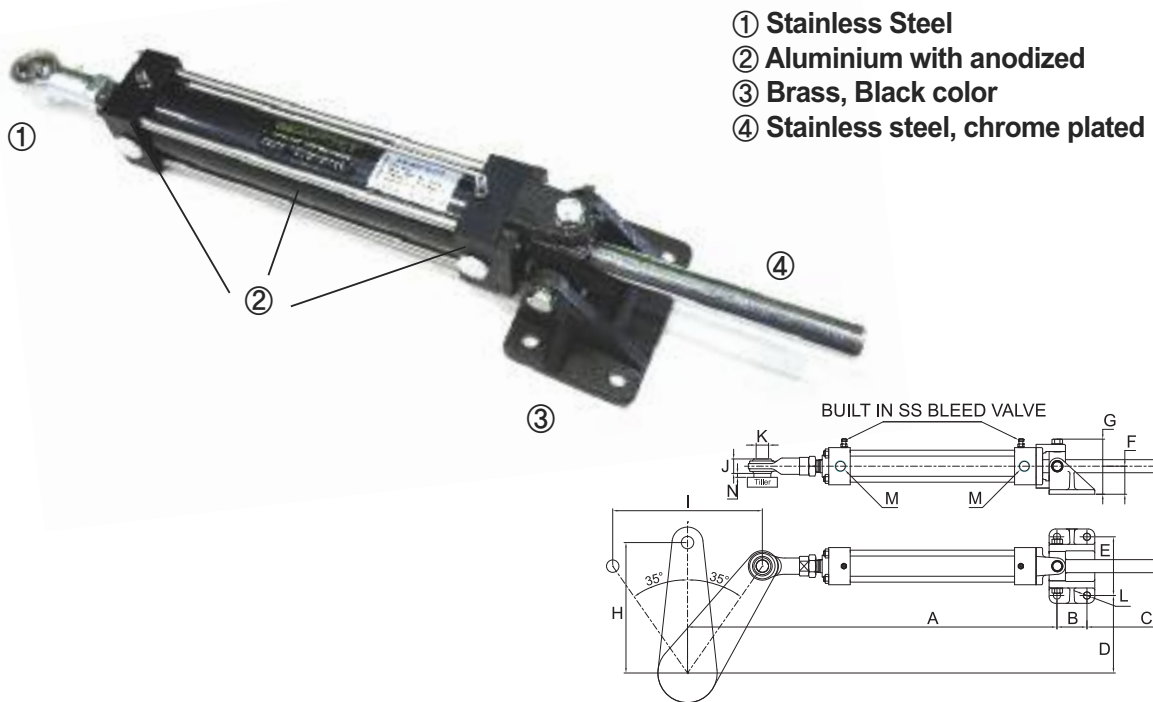

Model	A	B	C	D	E	F	G	H	I	J	K	L	N
IOC-4020	413	46	64	46	90	43	84	111	127	22	19.1	11	Min 6
IOC-4021	490	46	115	82	90	43	84	155	178	22	19.1	11	Min 6
IOC-4022	566	46	166	118	90	43	84	199	229	22	19.1	11	Min 6
IOC-5024	534	70	85	70	114	62	114	155	178	22	19.1	13	Min 6
IOC-5025	610	70	136	106	114	62	114	199	229	22	19.1	13	Min 6
IOC-5026	685	70	187	142	114	62	114	243	279	22	19.1	13	Min 6
IOC-6325	613	78	126	85	156	72	127	199	229	22	19.1	13	Min 6
IOC-6326	688	78	177	121	156	72	127	243	279	22	19.1	13	Min 6

TIE BAR

TBK 800S

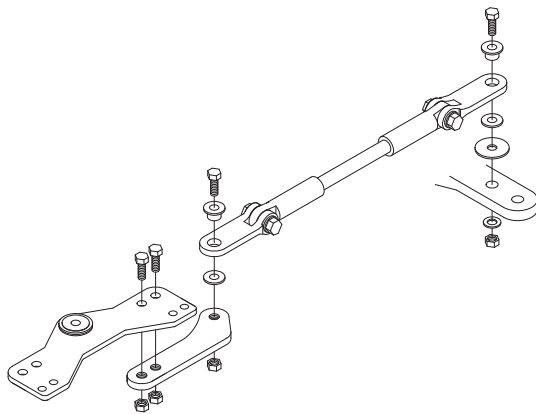
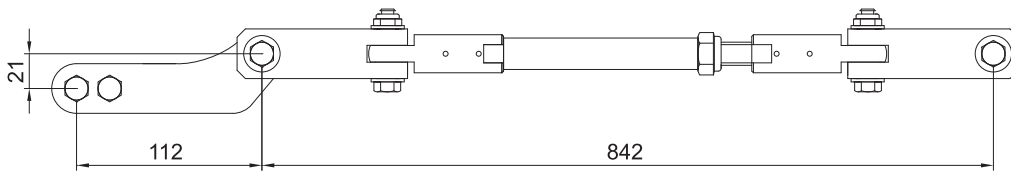

**Note : Applicable cylinder model
SOC 3520H-R1, SOC 3520V-Y1 and H1**

**Note :
Minimum engine center distance : 530mm
Maximum engine center distance : 1030mm**



TBK 800T

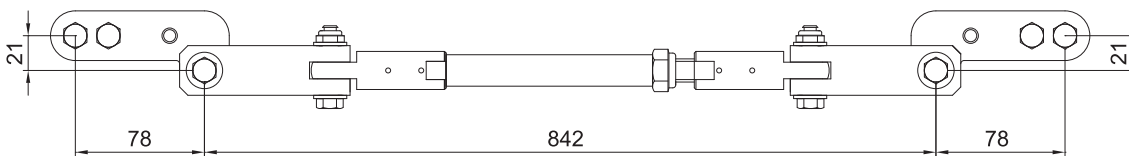

**Note : Applicable cylinder model
SOC 3520H-R1, SOC 3520V-Y1 and H1**

**Note :
Minimum engine center distance : 640mm
Maximum engine center distance : 1150mm**

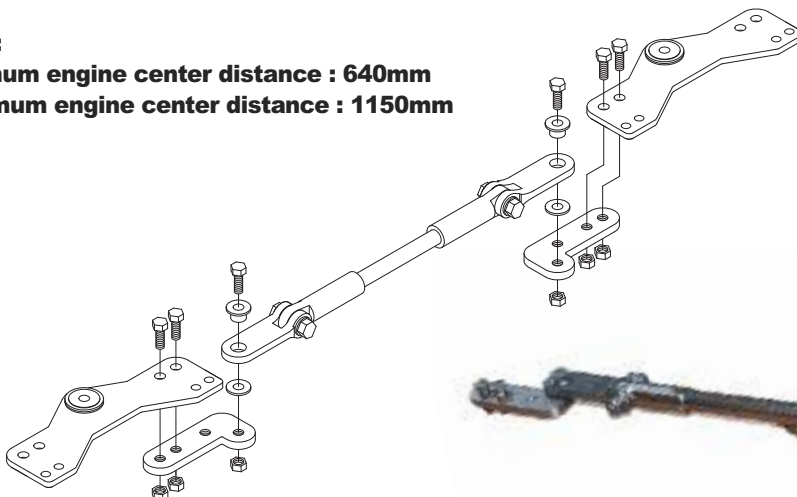

HOSE & HOSE COUPLING

HOSE KIT



Pre-assembled hose connectors on both ends Swaged type

Part Number	Description	Hose connector	Hose Size
NH 04-SS-01	Hose 1meter	G (PF) 1/4	1/4"
NH 04-SS-05	Hose 5meter	G (PF) 1/4	1/4"
NH 04-SS-06	Hose 6meter	G (PF) 1/4	1/4"
NH 04-SS-07	Hose 7meter	G (PF) 1/4	1/4"
NH 04-SS-08	Hose 8meter	G (PF) 1/4	1/4"
NH 04-SS-09	Hose 9meter	G (PF) 1/4	1/4"
NH 04-SS-10	Hose 10meter	G (PF) 1/4	1/4"
NH 04-SS-15	Hose 15meter	G (PF) 1/4	1/4"
NH 06-SS-01	Hose 1meter	G (PF) 3/8	3/8"
NH 06-SS-05	Hose 5meter	G (PF) 3/8	3/8"
NH 06-SS-06	Hose 6meter	G (PF) 3/8	3/8"
NH 06-SS-07	Hose 7meter	G (PF) 3/8	3/8"
NH 06-SS-08	Hose 8meter	G (PF) 3/8	3/8"
NH 06-SS-09	Hose 9meter	G (PF) 3/8	3/8"
NH 06-SS-10	Hose 10meter	G (PF) 3/8	3/8"
NH 06-SS-15	Hose 15meter	G (PF) 3/8	3/8"

* Other length : Production on demand



HOSE KIT with Bulkhead Mounting Plate (BMK16)

It is hose kit with pre-assembled Bulkhead Mounting Plate. For part number, add "B" on part number of hose kit. For example, NH06-SS-06B : 6meter hose kit with Bulkhead Mounting Plate



Bulkhead Mounting Plate (BMK16)

Part Number	Description	Suitable Hose
BMK16	Bulkhead Mounting Plate	NH04 (1/4"), NH06 (3/8")



Hose (roll)

Part Number	Description	Hose Size
NH 04	100meter	1/4"
NH 06	100meter	3/8"

Hose connector

Part Number	Spec	Material	Suitable Hose	Remark
SE-PF-04-14-S	G (PF) 1/4	Stainless steel	1/4"(NH 04)	Swaging type
SE-PF-04-14	G (PF) 1/4	Steel	1/4"(NH 04)	
SF-PF-06-14-S	G (PF) 3/8	Stainless steel	3/8"(NH 06)	
SF-PF-06-14	G (PF) 3/8	Steel	3/8"(NH 06)	
C3520149	G (PF) 3/8	Brass	3/8"(NH 06)	Reusable Hose Coupling
CPK0414	G (PF) 1/4	Steel	1/4"(NH 04)	Campuka

Swaging type



Reusable type



Campuka



FITTING

<p>HS38N0S</p> <p>SUS</p>	<p>HT14NNS</p> <p>SUS</p>	<p>HL14H0S</p> <p>SUS</p>	<p>HSO14H0</p> <p>STEEL, PLATED</p>	
<p>HTN300</p> <p>STEEL, PLATED</p>	<p>HL14N0S</p> <p>SUS</p>	<p>HLO14H0</p> <p>STEEL, PLATED</p>	<p>HLO14H0S</p> <p>SUS 316</p> <p>SUS 316</p>	
<p>HLO14B0</p> <p>STEEL, PLATED</p>	<p>HLO14B0S</p> <p>SUS 316</p> <p>SUS 316</p>	<p>HT14HHS</p> <p>SUS</p>	<p>HL38N0</p> <p>STEEL, PLATED</p>	
<p>HL14B0B</p> <p>Stainless steel</p>	<p>HTH300</p> <p>STEEL, PLATED</p>	<p>C3520122</p> <p>BLEED VALVE, for cylinder</p>	<p>HLO14N0S</p> <p>SUS 316</p>	<p>HSO14N0</p> <p>STEEL, PLATED</p>

Dual stations Fittings kit

Fittings kit	PARTS No	NO on picture	Q'ty / Kit	Application
NS-2NS-14	HSO14H0	②	2	NSH helm pump & NH 04 hose (1/4)
	HLO14H0	①	2	
	HTH300	③	2	
NS-2NS-38	HSO14N0	②	2	NSH helm pump & NH 06 hose (3/8)
	HLO14N0S	①	2	
	HTN300	③	2	
HP-2NS-38	HS38N0S	②	2	HP helm pump & NH 06 hose (3/8)
	HL38N0	①	2	
	HTN300	③	2	

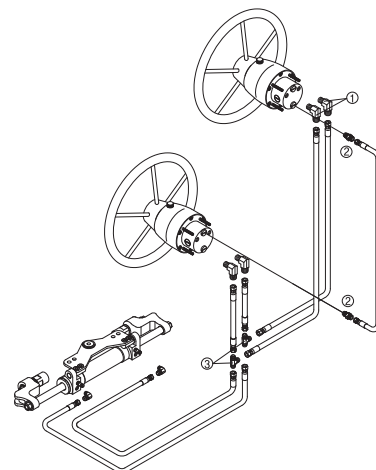

OIL BLEEDING KIT & TILLER ARM & OIL

Oil bleeding, Purging kit

Model OAK-100 for NSH helm pump
Model OAK 200 for HP helm pump



Tiller arm

- Reamer bolt, washers and Nut are supplied
- Tiller arm is made of steel with hard powder coating

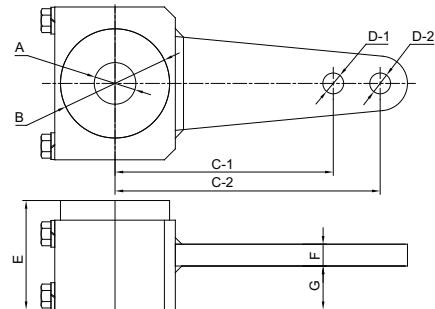

Parts Number	A	B	C-1	C-2	D-1	D-2	E	F	G	Application Cylinders
ST57-19S	25.4~60	80	111	/	19.1	/	70	15	27.5	IOC-4020
			/	155	/	19.1				IOC-4021 IOC-5024
ST09-19S	25.4~60	80	/	199	/	19.1	70	15	27.5	IOC-4022, IOC-5025, IOC-6325
ST911-19S	38.1~80	100	199	/	19.1	/	100	20	40	IOC-5026
			/	243	/	19.1				IOC-6326

Dimension : mm
For 70 degree angle use

Oil

Hydraulic steering require a good quality of hydraulic fluid, especially in case of manual hydraulic steering like outboard hydraulic steering. We highly recommend to use SAE NO 15 oil. Substitution of non-recommended fluid may result in heaving steering.



Model : SF OIL 15 (1liter bottle)

LIQUID TIE BAR ALIGNMENT VALVE



In case that the mechanical tie bar can not be used because of boat situation, the Liquid Tie Bar Alignment Valve can be used to allow for realignment of two outboard motors or two rudders. The use of mechanical tie bar is best. There is no substitute for mechanical tie bar.

Model LTB-14 for 1/4" tube line

Model LTB-38 for 3/8" tube line

STEERING WHEEL



SW-260



S01-350, S01-395



SW2 type

Model	Size	Material	Recommend
SW-260	Dia 260mm	Aluminium	Helm pump NSH 018, 022
S01-350	Dia 350mm	Stainless steel	Helm pump NSH 018, 022, 025, 030
SW2-60W	Dia 600mm	Mahogani wood	HP 4590T
S01-395	Dia 395mm	Stainless Steel	Helm Pump NSH 037, NSH 044

RUDDER ANGLE INDICATORS SYSTEM

RAI-S : Single Station

- Accurate, Durable needle movement
- Anti-corrosive black bezel
- Dimmer Switch
- LED on/off terminal
- Single and Dual station only
- Water resistant
- Fog resistant
- Led lighting



Part Number	Description	Source	Remark
DSR 110	Sensor	DC 8V ~ DC 36V	Include 10meter harness
DNR 104	Indicator 40-0-40		Dia 85mm
SFR 101	Indicator 45-0-45		Dia 85mm
SFR 102	Indicator 45-0-45 (Reverse)		Dia 85mm

RAI-M : Multi Stations

- Accurate, Durable needle movement
- Anti-corrosive black bezel
- Dimmer Switch
- LED on/off terminal
- Multi-Stations max 15 indicators
- Water resistant
- Fog resistant
- Led lighting

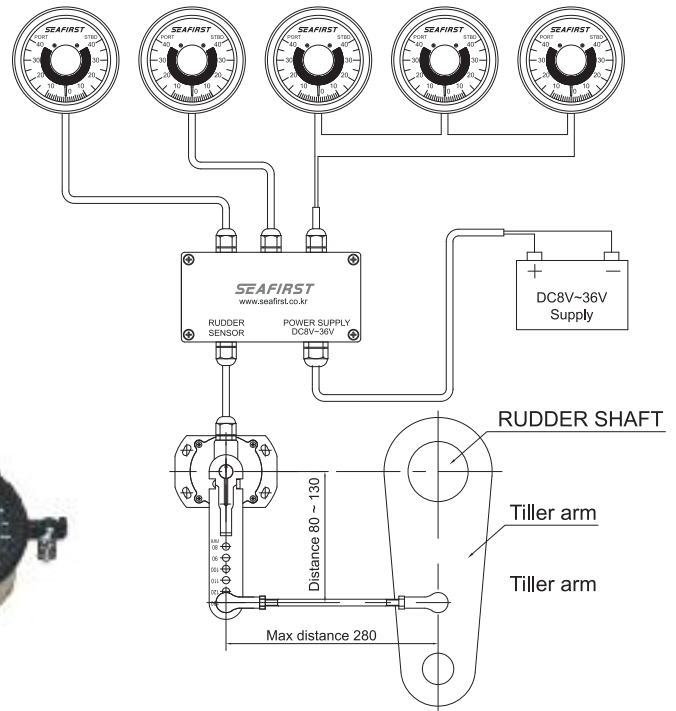

Part Number	Description	Source	Remark
DSR 110	Sensor	DC 8V ~ DC 36V	Include 10meter harness
DSR 104	Indicator 40-0-40		Dia 85mm
DSR 106	Distribution box		Dia 85mm
SFR 111	Indicator 45-0-45		Dia 85mm
SFR 112	Indicator 45-0-45 (Reverse)		Dia 85mm



경남 김해시 주촌면 골든루트로 66번길 48-5, 5동
전화 : 055) 338-1640 팩스 : 055) 338-1641
이메일 : info@seafirst.co.kr

#5, 48-5, Golden root-ro 66beon-gil, Gimhae-si, Gyeongsangnam-do, KOREA
Tel : +82-55-338-1640 Fax : +82-55-338-1641
<http://www.seafirst.co.kr>